

OPERATING, MAINTENANCE & PARTS MANUAL

OCEAN® HAND CHAIN HOIST

For hand chain hoist in capacities 0.5 ton through 30 ton

These Hand Chain Models meet or exceed the following standards:



AS1418.2

ANSI B30.21

ANSI B30.16

Plus:



IF YOUR HOIST WILL NOT ACTIVATE

We commonly see this occur when the overload protection has engaged, signaling your load is heavier than the hoist is rated for. Check hoist capacity against load weight.



Before using the hoist, fill in the information below:

Capacity: _____

Model No.: _____

Serial No.: _____

Date: _____



CONTENTS

General Information 3

Hoist Construction

Terms & Summary

Safety Precautions 3

Signal Words – Danger, Warning,
Caution & Notice

Warning Tag 4

Safety Rules 4

Inspection Before Initial Use 5

Installation

Operation

To Avoid Injury: Do's & Don't 6

Operating the Hoist & Handling the Load 8

To Operate the Hoist

Attaching the Load

Lifting the Load

Maintenance 9

Testing

Preventative Maintenance

Inspections 10

Schedule

Frequent Inspection

Periodic Inspection

Exceptions

Chain

Hooks 11

Inspection Chart 12

Lubrication 12

General

Gears 13

Chain 13

Overload Protection 13

Parts List & Exploded View 14

Dimensions & Specifications 15

Ocean[®] Hoist Warranty 16

Warranty Coverage

Warranty Claim Procedure

GENERAL INFORMATION

This document provides information and maintenance of Ocean[®] Hand Chain Hoists. People who are operating or maintaining the hoist should be familiar with this manual. Following the precautions, procedures and maintenance practices in this manual should ensure long and reliable operation. People responsible for the installation, operation, and/or maintenance of the this hoist should be familiar with the American National Standard ANSI B30.16 for guidelines on the safe operation of hoists.

This document and ANSI B30.16 must be read and understood by all individuals before they install, operate or maintain this equipment.

HOIST CONSTRUCTION

This hand chain hoist is an efficient means of lifting freely suspended material loads within its load rating. This chain hoist's construction conforms to applicable ANSI B30.16 guidelines and is built to withstand stresses imposed under normal operating conditions while handling loads within its load rating. The frame and covers of the hoist are made from stamped steel construction. The cast hand chain wheel and load activated break will provide smooth, precise spotting of loads.

SAFETY PRECAUTIONS

SIGNAL WORDS – DANGER, WARNING, CAUTION & NOTICE

Throughout this manual, there are steps and procedures that can present hazardous situations. The following signal words are used to identify the degree or level of hazard seriousness.

DANGER indicates an imminently hazardous

TERMS & SUMMARY

This manual provides important information for personnel involved with the installation, operation, and maintenance of the hoist. It is the responsibility of the owner/user to install, inspect, test, maintain an operate this hoist in accordance with applicable ANSI standards.

These general instructions deal with the normal operation and maintenance situations encountered with the products described herein.

This product should not be installed, operated or maintained by any person who has not read all of the contents of these instructions. Failure to read and comply with these instructions or any of the warnings or limitations noted herein can result in serious bodily injury or death, and/or property damage.

Only trained and qualified personnel shall operate and maintain this equipment.

Equipment described herein is not designed for, and shall not be used for lifting, supporting or transporting people.

Modifications to up-grade, re-rate or otherwise alter these products can only be authorized by the manufacturer.

situation which, if not avoided, will result in death or serious injury and property damage.

WARNING indicates an imminently hazardous situation which, if not avoided, could result in death or serious injury and property damage.

CAUTION indicates a potentially hazardous situation which, if not avoided, may result in minor or moderate injury or property damage.

NOTICE is used to notify people of installation, operation or maintenance information which is important but not directly hazard related.



These general instructions deal with the normal installation, operation, and maintenance situations encountered with the hoists referenced in this manual. The instructions should not be interpreted to anticipate every possible contingency or to anticipate the final system, crane, or configuration that uses this hoist. For systems using a hoist in this manual, the supplier and owner of the system are responsible for the system's compliance with all applicable industry standards, and with all applicable federal, state and local regulations/codes.

WARNING TAG

Ocean[®] hoists are supplied from the factory with a warning label as depicted in Figure 1. Operators are to read and obey all warnings. This label is to remain on the hoist and legible at all times. Replacement label can be supplied by your Ocean[®] distributor.



Figure 1

SAFETY RULES

Inspect the hoist for loose, broken or malfunctioning parts. Any hoist should be tagged "out of order" and taken out of service until the problem is corrected.

DO NOT overload the hoist.

DO NOT side load the hoist. Make sure to pull in the straight line between hooks. Side loading the hoist over a sharp corner may fracture the hoist housing, load block or hook.

Be sure there are NO twists in the chain. Make sure that the load chain is free to move and clear all obstructions. With multiple chained hoists the load hook can be turned one or more times causing the chain to twist.

DO NOT use the hoist from an unbalanced/unstable position. Operators should have firm footing or be secured before operating the hoist.

Before raising and/or pulling a load always make sure that the slings and other rigging have sufficient capacity to support the load, and are in good condition.



DO NOT STAND BENEATH A SUSPENDED LOAD OR WALK UNDER A SUSPENDED LOAD!

DO NOT operate a load in a way to endanger personnel.

DO NOT leave the hoist with a suspended load.

DO NOT wrap the load chain around the load. USE A SLING!

DO NOT TIP-LOAD the hook, as this will exert undue strain, resulting in hook failure.

The hoist is designed for manual operation by one person only. DO NOT operate the hoist with other power besides the manual power from one person. (See Table 1 for each hoist's rated effort/force to raise capacity loads.)



WARNING

DO NOT USE THIS HOIST TO LIFT, SUPPORT OR OTHERWISE TRANSPORT PEOPLE OR LIFT LOADS OVER PEOPLE.

The hand chain has at least one safety connector link. When any safety connector link opens or deforms, stop immediately to find out the cause.

NEVER use the chain or hook as a ground welding.

Use only Ocean[®] original replacement parts and chains supplied by an authorized Ocean[®] dealer.

NEVER intentionally lower the hoist load chain out/down so-as to force tension on the lower limit stop device.

INSPECTION BEFORE INITIAL USE

After unpacking the hoist, inspect carefully for any damage that may have occurred during shipping. Check for loose, missing or damaged parts.



WARNING

DO NOT install or use a damaged product.

Before initial use record the Capacity, Model, Serial Number and Date of Purchase in the space provided on the front cover of this manual.

INSTALLATION

Be sure that the hoist is suspended or connected to a supporting structure that is strong enough to support the full rated load of the hoist using a generous factor of safety. The hoist body must be allowed to freely align itself between the two hooks. The load path, or path of force, between the top hook and the bottom hook must be in a straight line and shall not be deflected or bent. Do not allow any part of the hoist frame/body to rest against or make contact with any object or supporting structure.

OPERATION

Before Initial Operation:

Read and comply with all instructions & warnings furnished with or attached to this hoist as applicable.

Read and comply with ANSI B30.16 guidelines for operation.

Check that the hoist and chain is lubricated.

Check that the chain is not damaged, deformed, kinked or bent.

Where applicable, check that the chain is properly seated in sheaves and that chain is not twisted. (*see figures 2 and 3*)

Check operation of the brake by lifting the load slightly, stopping then observing for drift or slippage.

Before Each Shift:

Inspect hooks for nicks, gouges, cracks, and sign of pulling apart or twisting.

Inspect hook latch for proper operation.

Check chain for kinks, twists, bent links, gouges, welding arcs, deformed links, damage or deterioration.

Check operation of the brake by lifting a load slightly and observing for drift or slippage.

Replace warning labels if damaged, obscured or missing.

Before Operating:

Be certain that all personnel are clear of the load to be lifted and moved.

Make sure load will clear stock piles, machinery, or other obstructions when hoisting and traveling the load.

Check to see that the hoist is connected to a structure that will safely support the weight of the load and the weight of the hoist.

Check to see that the hoist is allowed to freely align itself in a straight load path between the upper and lower hook.

Check to see that the hoist frame does not touch anything as the load is applied.

Operate the hand chain up & confirm an audible clicking sound and that the chain is not stiff or binding.

Operate the hand chain down & confirming that the hand chain movement is not stiff or binding.

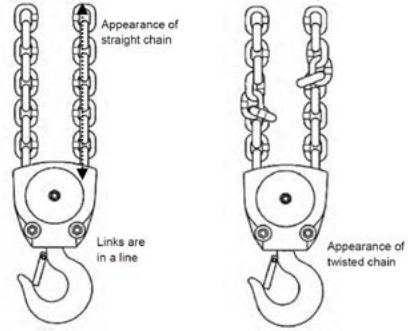

Figure 2

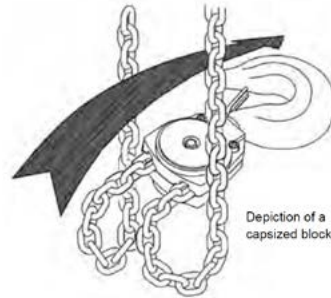

Figure 3



TO AVOID INJURY: DO'S & DON'T

These recommendations apply to all hand chain manually operated chain hoists for vertical lifting service involving material handling of freely suspended unguided loads.

- DO read ANSI B30.16 Safety Standard for Overhead Hoists and Hoist and Manufacturer's Operating, Maintenance and Instructions.
- DO familiarize yourself with the operating control and procedures for the hoist.
- DO make sure the suspension hook for the hoist is securely attached to an appropriate support.
- DO establish firm footing or be otherwise secured when opening the hoist.

- DO make sure that load slings or other approved attachments are sized properly and seated correctly in the hook saddle.
- DO make sure the hook latch is closed and not supporting any part of the load.
- DO make sure the load is free to move and will clear all obstacles.
- DO make sure all persons stay clear of the suspended load.
- DO avoid swinging of the load or load hook.
- DO protect load chain from weld spatter or other damaging contaminants.
- DO promptly report any malfunction, unusual performance, or damage of the hoist.
- DO inspect hoist regularly, replace damaged or worn parts, and keep appropriate records of maintenance.
- DO use the hoist manufacturer's recommended part when repairing a hoist.
- DO apply lubricant to load chain as recommended by the hoist manufacturer.
- DO NOT lift more than rated load.
- DO NOT use the hoist load-limiting device to measure the load.
- DO NOT use damaged hoist or hoist that is not working correctly.
- DO NOT use hoist with twisted, kinked, damaged or worn chain.
- DO NOT lift a load unless chain is properly seated in chain wheel(s) or sprockets(s).
- DO NOT use load chain as a sling or wrap load chain around the load.
- DO NOT lift a load if any binding prevents equal loading on all supporting chains.
- DO NOT apply the load to the tip of the hook.
- DO NOT operate unless load is centered under hoist.
- DO NOT operate hoist with other than manual power.
- DO NOT permit more than one operator to pull a single hand chain at one time.
- DO NOT jerk or yank the hand chain.
- DO NOT allow your attention to be diverted from operating the hoist.
- DO NOT intentionally force the hoist load chain down / out to the end of it's travel and impose tension on the limit device bracket.
- DO NOT intentionally raise or draw the load hook / block into the hoist body.
- DO NOT use hoist to lift, support, or transport people.
- DO NOT lift loads over people.
- DO NOT leave a suspended load unattended unless specific precautions have been taken.
- DO NOT allow sharp contact between two hoists or between hoist and obstructions.
- DO NOT allow the chain or hook to be used as a ground for welding.
- DO NOT allow the chain or hook to be touched by a live welding electrode.
- DO NOT remove or obscure the warnings on the hoist.
- DO NOT adjust or repair a hoist unless qualified to perform hoist maintenance.
- DO NOT attempt to lengthen the load chain or repair damaged load chain.
- DO NOT throw the hoist.
- DO NOT strike the hoist with a hammer or other objects.

OPERATING THE HOIST & HANDLING THE LOAD

TO OPERATE THE HOIST

While facing the side of the hoist with the hand chain cover:

Pull by hand, the hand chain from the right side (*clockwise*) to raise or draw the load hook up or toward the hoist body.

Pull by hand, the hand chain from the left side (*counterclockwise*) to lower or pay out the load hook down or away from the hoist body. (See figure 4)

ATTACHING THE LOAD

The load should be attached to the hook with slings or other appropriate devices. Do not wrap the load chain around a load.

Be sure the load is supported in the saddle of the hook and the latch is closed. Do not lift a load that is unbalanced or could become unbalanced as it is lifted. Do not lift a load on the tip of the hook.

All below hook lifting devices shall be used in accordance with ANSI B9 (*related to the use of Slings*) and ANSI B30.20 (*related to the use of Below Hook Lifting Devices*)

LIFTING THE LOAD

Raise the load by pulling the right side hand chain. Lift the load just clear of the floor. Check the ability of the brake to hold the load. Check

that the sling is secure in the hook and that the load is well balanced. After confirming, proceed with raising the load.

Lift the load to the desired height, standing clear of the load.

Lower the load by pulling the left side hand chain. Pull smoothly and slowly. Do not “spin” the hand chain.

Do not jam the hook block into the bottom of the hoist, or run the hook down until the slack chain is pulled tight.

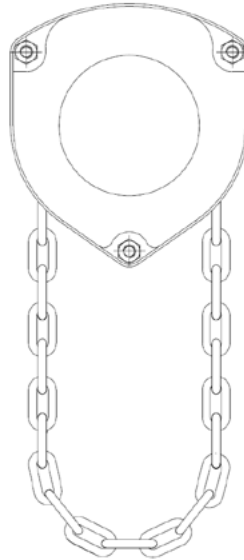

Figure 4

MAINTENANCE

Never perform maintenance on hoist while it is supporting a load.

Before performing maintenance, tag hoist:

WARNING - DO NOT OPERATE – EQUIPMENT BEING REPAIRED.

Only allow personnel trained in operating and servicing this product to perform maintenance.

TESTING

After performing maintenance on the hoist, test to at least 100% but less than 125% of its rated capacity before returning to service. Testing to more than 125% of rated capacity might be required to comply with standards and regulations set forth in areas outside of the USA.

NOTICE

The following instructions provide general information to disassemble, inspect, repair, and assemble the hoist. Hoist exploded view drawings are provided in "PARTS" section. Maintenance shall only be performed by designated individuals. It is strongly recommended that the hoist be sent to an authorized service dealer for inspection, service, repair or maintenance.

If a hoist is being completely disassembled for any reason, follow the order of the topics as they are presented. It is recommended that all maintenance work be performed on a bench.

In the process of disassembling the hoist, observe the following:

Never disassemble hoist any further than is necessary to accomplish needed repair. A good part can be damaged during the course of disassembly.

Never use excessive force when removing parts. Tapping gently around the perimeter of a cover or housing with a soft hammer, for example, is sufficient to break the seal.

Do not apply heat to a part to free it for removal. In general terms, the hoist is designed to permit easy disassembly and assembly. Use of heat or excessive force should not be required.

Keep work area as clean as practical, to prevent dirt and other foreign matter from getting into bearings or other moving parts.

When grasping a part in a vise, always use leather-covered or copper-covered vise jaws to protect the surface of the part and help prevent distortion. This is particularly true of threaded members, machined surfaces and housings.

PREVENTATIVE MAINTENANCE

It is necessary to conduct regular and scheduled inspection and lubrication of this hoist to enable safe, lengthy and satisfactory operation. Recommended inspection matter and intervals are given in the INSPECTION section of this manual. The owner / operator should increase or decrease these inspection intervals based on usage and experience.

INSPECTIONS

SCHEDULE

Frequent and periodic inspections are thorough examinations conducted by personnel trained in the safety, operation and maintenance of this equipment. ASME B30.16 states inspection intervals depend upon the nature of the critical components of the equipment and severity of usage.

Careful inspection on a regular basis will reveal potentially dangerous conditions while still in the early stages, allowing corrective action to be taken before the condition becomes dangerous.

Deficiencies revealed through inspection, or noted during operation, must and shall be reported to designated personnel trained in safety, operation and maintenance of this equipment.

A determination as to whether a condition constitutes a safety hazard must be decided, and the correction of noted safety hazards accomplished and documented by written report before placing the equipment in service.

Prior to initial use, all new, modified and repaired products shall be inspected in accordance with all items in Table 2. Thereafter, items to be inspected are indicated in Table 2 by Frequent or Periodic designation.

FREQUENT INSPECTION

On a hoist in continuous service, frequent inspections should be conducted at the beginning of each shift. In addition, visual inspections should also be conducted during regular service for any damage or evidence of malfunction which appears between regular inspections. This inspection includes listening for unusual sounds while the product is being operated that may indicate deficiencies.

PERIODIC INSPECTION

Frequency of periodic inspection depends on the severity of usage:

Normal Usage — Annually

Heavy Usage — Semiannually

Severe Usage — Quarterly

Audible coupled with visual inspection according to the items listed in Frequent designation. Some disassembly is required to allow a more detailed inspection if external conditions indicate the need.

EXCEPTIONS

Brakes require more than audible / visual inspection. Check daily by operating the product with and without a load, stopping at various positions to ensure safe operation.

CHAIN

Inspect chain before each use. Between regular inspections, check visually daily for nicks, gouges, weld splatter, corrosion, or distorted links. Inspect chain thoroughly if it does not feed smoothly over load sheaves.

Inspect as follows:

Clean chain before inspection.

Test hoist with load and observe operation of chain as it passes over load sheaves

Slacken chain and inspect contact points for excessive wear.

See Figure 7

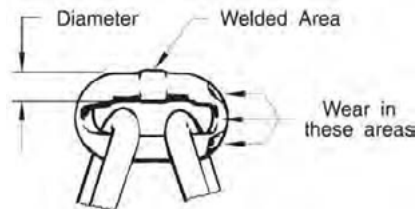

Figure 7

HOOKS

Any hook that requires replacement because of excessive bends, twists, or throat opening indicates abuse or overloading the hoist. Therefore, other load supporting components of the hoist should be inspected for possible damage when such conditions are found.

Never repair hooks. Never weld or reshape a hook. Never heat a hook. Heat applied to the hook will alter the original heat treatment of the hook material and reduce the strength of the hook.

Never weld handles or other attachments to the hook.

Hook Inspection:

Where applicable, inspect hooks and measure throat opening at least once per month. Between regular inspections check visually daily for deformation, distortion, twisting, damage, and missing or damaged hook latches.

Hooks damaged from chemicals, deformations or cracks, or that have more than 10 degree twist from the plane of an unbent hook or excessive opening or seat wear, must be replaced. (See Figure 5)

Also, hooks that are opened to the extent that the latch does not engage the tip must be replaced. (See Figure 6 and Table 3 for hook retirement/replacement criteria)

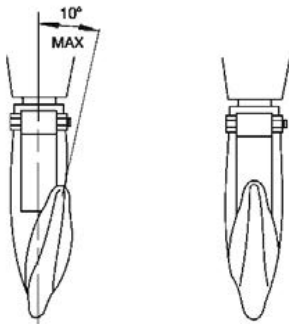

Figure 5

Hook Opening:

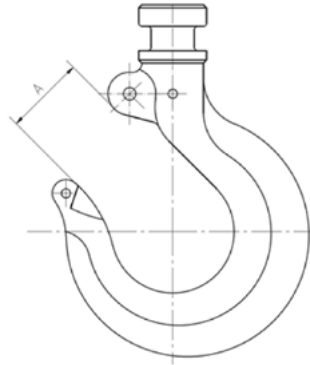

Figure 6

REPLACE HOOK WHEN OPENING IS GREATER THAN	HOIST CAPACITY (TONS)
0.9in (23.1mm)	0.5
1.07in (27.3mm)	1.0
0.99in (25.2mm)	1.5
1.27in (31.5mm)	2.0
1.57in (39.9mm)	3.0
1.81in (46.2mm)	5.0
2.65in (67.2mm)	10.0

Table 3

INSPECTION CHART

ITEM	LOCATION	CHECK / INSPECT FOR	FREQ.	PER'D
Braking Mechanism		Slipping under load; jumping; jolting	x	x
		Hard or difficult to release	x	x
Brake Discs		Glazing; cracks; crushing; deformation; thickness		x
		Oil contamination; chemical contamination		x
Brake Parts	Pawl - Ratchet	Excessive wear; deformation; fit; corrosion		x
	Pawl - Spring	Stretch; deformation; corrosion		x
Hooks – Top & Bottom		Chemical damage; corrosion; welding arcs	x	x
		Deformation; gouging; heat damage	x	x
		Cracks: use dye penetrant, magnetic particle or other suitable detection method		x
Hook Retaining Members – Pins, brackets, bolts, nuts		Tightness, wear, corrosion, deformation, secure	x	x
Hook Latch		Damage; deformation; proper operation	x	x
Suspension Members – Sheaves, hand-wheels, chain attachments, suspension bolts		Excessive wear; looseness, deformations	x	x
		Cracks; breaks		x
Gears & Shafts		Distortion, damaged threads		x
		Broken or worn teeth		x
		Cracks		x
		Proper lubrication		x
Load Block – Suspension Housing		Distortion; cracks; accumulation of foreign deposits; wear; damage; missing or loose parts	x	x
Trolley – Supporting structure		Continuing ability to support rated loads		x
Bolts, Nuts, Rivets, hardware		Tightness; security; wear; damage or corrosion	x	x
Chain End Anchor		Distortion; deformation and attachment	x	x
WARNING Label		Present and legible	x	x

LUBRICATION

All internal operating parts of an Ocean[®] hand chain hoist that require lubrication are pre-lubricated at the time of assembly by the factory. Re-lubrication is recommended at intervals according to Periodic Inspection. However, re-lubrication may be required more frequently based on type and severity of service.

GENERAL

The use of anti-seize compound (***) is recommended on internal threaded components. Unless otherwise stated, remove old lubricant, clean the part with an acid free solvent and apply a new coating of lubricant to the part before assembly. Lubricant should cover all necessary surfaces evenly without gaps in coverage.

Do not apply lubricant to brake friction disk or brake surfaces. Do not allow excess lubricant to make contact with the brake friction disk or brake surfaces.

The brake surfaces must be kept free of any trace of oil, grease or lubricant. Apply lubricant to parts near the brake neatly, evenly and in measured amounts. Keep the lubricant localized on the part being lubricated to avoid contamination of the brake and brake surfaces. *(adjacent text to caution box)*

GEARS

Unscrew nuts in the opposite side of the hoist as the hand chain, and remove gear cover and support plate. Remove old grease and replace with new. For hoist operating in temperatures from -20 degrees to 50 degrees Fahrenheit; use EP1 grease or equivalent. For hoists operating in temperatures from 30 degrees to 120 degrees Fahrenheit use EP2 grease or equivalent.

OVERLOAD PROTECTION

You have purchased an Ocean[®] hand chain hoist fitted with overload protection. The following information should be read in conjunction with all other information contained in this manual;

The "Load Safe" overload protection consist of the components shown as sub-parts of part #19-1 in the exploded view of the product.

The overload protection is calibrated at the time of manufacture and should not require re-calibration if the hoist is used as intended.

CHAIN

Lubricate each link of the load chain weekly. Work lubricant into the area where the links contact each other. Apply new lubricant over existing layer.

In severe usage applications, aggressive or corrosive environments, lubricate more frequently than normal.

Lubricate hook and hook latch pivot points with the same lubricant used on the load chain.

Do not apply lubricant to the hand chain.

To remove rust or abrasive dust build-up. Clean chain with acid free solvent. After cleaning, lubricate the chain.

Use SAE 50 to 90EP oil.

** Recommend – Loctite[®] Nickel-Based High Performance N-5000[™] High Purity Anti-Seize paste.

The overload clutch can be re-calibrated using factory supplied tools available only to Ocean[®] repair agents.

In the unlikely event of the overload clutch being damaged, complete replacement kits are available. Individual clutch components are NOT available.

PARTS LIST & EXPLODED VIEW

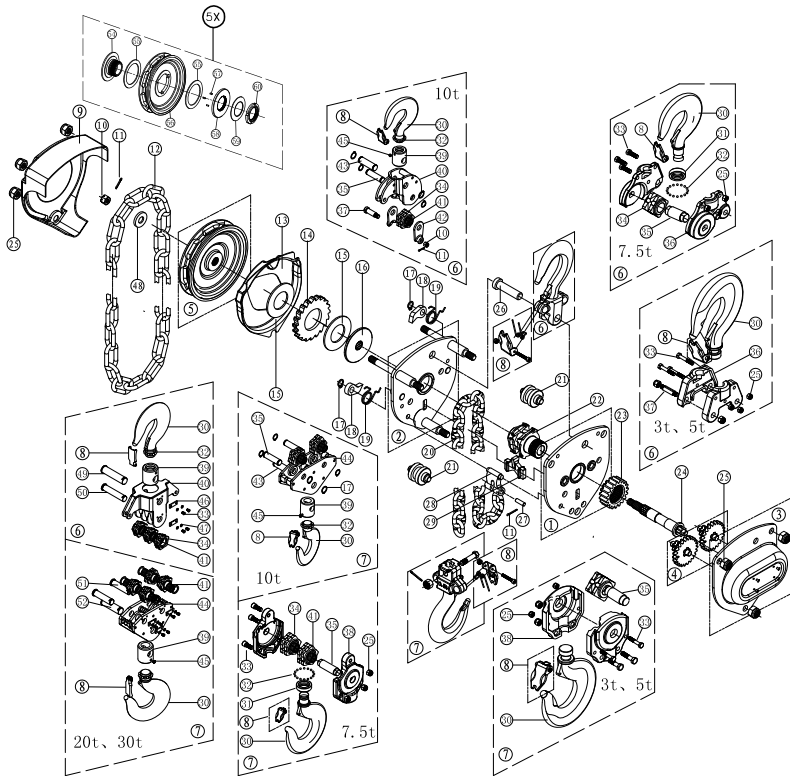

1	Gear side plate assembly	14	Ratchet disc	27	Tail chain pin	40	Top hook frame set	53	Cross screw
2	Brake side plate assembly	15	Friction disc	28	End anchor	41	Roller needle		
3	Gear case assembly	16	Break seat	29	Stripper	42	Chain sling plate		
4	Disc gear assembly	17	Snap ring	30	hook	43	Hook shaft		
5	Hand chain wheel	18	Pawl	31	Bearing ring	44	Book hook frame set		
6	Top hook assembly	19	Pawl spring	32	Roll ball	45	Holding screw		
7	Bottom hook assembly	20	Load chain	33	Hex bolt	46	Baffle		
8	Safety latch assembly	21	Guide roller	34	Deflector wheel	47	Spring washer		
9	Hand wheel cover	22	Load sheave	35	Deflector wheel pin	48	Washer		
10	Castle nut	23	Splined gear	36	Top hook frame	49	Top hook shaft		
11	Split pin	24	Drive shaft	37	Chain pin	50	Deflector wheel pin		
12	Hand chain	25	Lock nut	38	Bottom hook frame	51	Deflector wheel pin		
13	Ratchet disc cover	26	Top hook shaft	39	Load hook bracket	52	Bottom hook shaft		

DIMENSIONS & SPECIFICATIONS

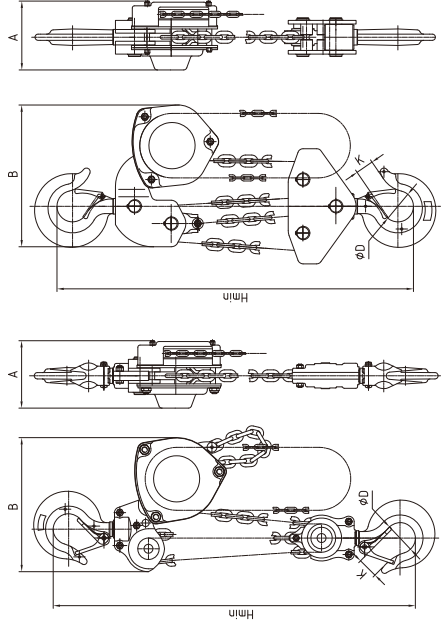
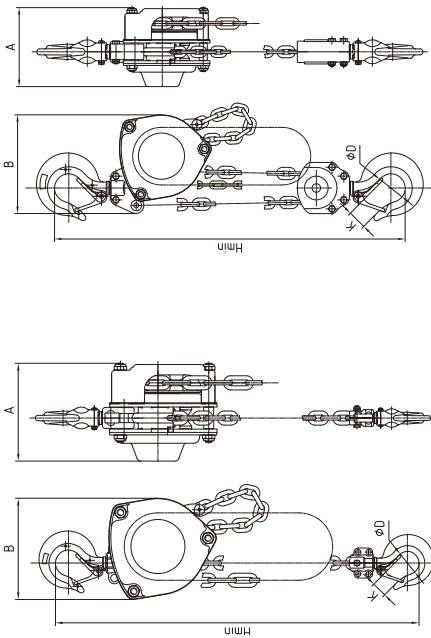

Ocean® Brand Chain Hoist Capacities (tons)

	0.5T	1.0T	1.5T	2.0T	3.0T	5.0T	10T	
Model	OCN-CH0.5	OCN-CH1.0	OCN-CH1.5	OCN-CH2.0	OCN-CH3.0	OCN-CH5.0	OCN-CH10	
Capacity (lbs.)	1100	2200	3300	4400	6600	11000	22000	
Dimensions (in.)	A	5.04	5.45	6.34	6.34	6.34	709	7.64
	B	4.80	5.83	6.89	6.89	9.13	10.16	15.12
	H-min	11.61	13.58	16.14	16.97	16.30	23.62	31.42
	D	1.38	1.57	1.77	2.05	2.17	2.68	3.35
	K	0.87	1.02	1.14	1.38	1.54	1.69	2.28
Net Weight (with 10' of chain)	16.98	24.47	36.82	38.80	54.67	86.42	184.97	
Load Chain (mm)	5X15	6X18	8X24	8X24	10X30	10X30	10X30	
Strands of Load Chain (#)	1	1	1	1	2	2	4	
Effort Required to Lift Rated Load (lbf.)	47.21	66.99	82.73	96.67	85.2	103.41	109.71	
Strands Lift	Depends on selected chain length: No Chain, 10 ft., 15 ft., or 20ft.							
SKU by Chain Length	No Chain	OCN-CH0.5NC	OCN-CH1.0NC	OCN-CH1.5NC	OCN-CH2.0NC	OCN-CH3.0NC	OCN-CH5.0NC	OCN-CH10NC
	10' Chain	OCN-CH0.5-10	OCN-CH1.0-10	OCN-CH1.5-10	OCN-CH2.0-10	OCN-CH3.0-10	OCN-CH5.0-10	OCN-CH10-10
	15' Chain	OCN-CH0.5-15	OCN-CH1.0-15	OCN-CH1.5-15	OCN-CH2.0-15	OCN-CH3.0-15	OCN-CH5.0-15	OCN-CH10-15
	20' Chain	OCN-CH0.5-20	OCN-CH1.0-20	OCN-CH1.5-20	OCN-CH2.0-20	OCN-CH3.0-20	OCN-CH5.0-20	OCN-CH10-20

OCEAN[®] HOIST WARRANTY

WARRANTY COVERAGE

All Ocean[®] Hoist products are warranted to be free from defects in materials and workmanship for 2 years from the date of shipment.

All manual hoist products carry a 2 year warranty.

This warranty applies only when the product is used in accordance with manufacturer's recommendations and does not extend to products that have been:

- Overloaded, misused, or abused
- Altered or repaired by unauthorized personnel
- Improperly maintained
- Exposed to improper installation or adverse environmental conditions
- Subject to normal wear and tear of moving parts

WARRANTY CLAIM PROCEDURE

Visit www.oceanproducts.com/warranty-information to register your product or to initiate a warranty claim.

Notification: Buyer must notify Ocean[®] immediately upon discovery of an alleged defect.

Return Authorization: Obtain a Return Goods Authorization (RGA) from Ocean[®] prior to shipping any product.

Documentation: Include proof of purchase and a detailed description of the defect.

Shipping: Ship the product freight prepaid to an authorized Ocean[®] warranty depot.

Inspection: Ocean[®] will inspect the product to confirm whether a defect exists.

If a defect is confirmed, Ocean[®] will repair or replace the product at no additional cost to the Customer.

If no defect is found, or the defect is due to causes excluded in this warranty, Ocean[®] will return the item, unmodified, to the customer. Customer is responsible for prepayment of return shipping costs.

Post-Repair Coverage: Warranty coverage on repaired or replaced products continues for the remainder of the original warranty period.

Limitations of Liability

Ocean[®] shall not be liable for:

- Injury to persons or damage to property
- Incidental, consequential, or special damages
- Losses arising from misuse, negligence, or failure to follow installation/operating instructions

This warranty constitutes the only written warranty and replaces any other implied warranties, including merchantability or fitness for a particular purpose.